

PASSENGER DOORS - MAINTENANCE PRACTICES

1. General

A. This section provides maintenance practices, test procedures, and removal/installation for passenger doors.

2. Upper Passenger Door Removal/Installation

A. Remove Upper Passenger Door (Refer to Figure 201).

- (1) Remove split ring from lower door cable.
- (2) Remove safety clips (20A) from both end of each gas spring (12) and remove gas springs.
- (3) Remove screws (8) attaching upper passenger door hinge (4) to fuselage above door jamb.

NOTE: If upper door gas spring is removed, it should be tagged to identify it as being used on upper door. Upper door gas spring and lower door dampener are identical except for pounds of force. Upper gas spring has 45 pounds of force (Airplanes 20800001 Thru 20800058), or 60 pounds of force (Airplanes 20800059 and On). Lower door dampener has 6 pounds of force (Airplanes 20800001 Thru 20800095 Except Airplanes incorporating CAB86-11); or 10 pounds of force (Airplanes 20800096 and On, and 20800001 Thru 20800095 Incorporating CAB 86-11). They both have the same placard installed on cylinder. To determine difference between upper gas spring and lower door snubber, push in on cylinder rod. If rod can be compressed easily, the cylinder is a lower door dampener. If rod cannot be compressed easily, the cylinder is an upper door gas spring. If upper door gas spring or lower door dampener are replaced with a new part, the replaced part must be disposed of in accordance with Cargo Door - Maintenance Practices, Disposal of Gas Spring Cylinder.

B. Install Upper Passenger Door (Refer to Figure 201).

- (1) Align holes in upper passenger door hinge (4) with holes in fuselage above door jamb and install screws (8).
- (2) Place ends of gas springs (12) over ballstuds (20B) and install clips (20A).
- (3) Install split ring on door pullstrap around lower cable.
- (4) Make sure the door gap is correct. Refer to Passenger Door Gap Adjustment in this section.

3. Upper Passenger Door Latching Mechanism Removal/Installation

A. Remove Upper Passenger Door Latching Mechanism (Refer to Figure 201).

- (1) Remove roll pin (48), handle (50) and washer (47).
- (2) Remove door window trim moulding.
- (3) Remove roll pin (21) outside handle (24) and washer (23).
- (4) Remove cotter pin (67), washer (66) and lock pin (69).
- (5) Remove screw (25), nut (27), washer (26), screw (22), and guide (70).
- (6) Remove escutcheon (72).
- (7) Remove washers (28), cotter pin (57), pin (30) and spindle (46).
- (8) Remove two screws (45), nut (43), washer (44), washer (52), screw (51), screw (55) and support (56).
- (9) Remove bellcrank (41) by removing cotter pins (29) and pins (42).
- (10) Remove cotter pin (62), pin (60), pushrod (59) and latch pin assembly (61).
- (11) Remove cotter pin (31), pin (39), pushrod (40) and latch pin assembly (37).

B. Install Upper Passenger Door Latching Mechanism (Refer to Figure 201).

- (1) Install latch pin assembly (37) and connect pushrod (40) to latch pin using pin (39) and cotter pin (31).
- (2) Connect pushrod (40) to bellcrank (41) using pin (42) and cotter pin (29).
- (3) Install latch pin assembly (61) and connect to pushrod (59) using pin (60) and cotter pin (62).
- (4) Connect pushrod (59) to bellcrank (41) using pin (42) and cotter pin (29).
- (5) Install support (56) using two screws (45), screw (55), screw (51), washer (52), washer (44), and nut (43).
- (6) Insert spindle (46) through bearing (52A), support (56) and bellcrank (41). Secure to bellcrank (41) using pin (30) and cotter pin (57).
- (7) Install washers (28) on spindle (46).

- (8) Insert escutcheon (72) through hole in door and onto spindle (46), then install lock pin guide (70) using screw (22), washer (26), nut (27) and screw (25).
- (9) Insert lock pin (69) into guide (70), and attach to door lock cam using washer (66) and cotter pin (67).
- (10) Install washer (23) over spindle (46), then install outside handle (24) and secure with roll pin (21).
- (11) Install door window trim moulding.
- (12) Install washer (47) and interior handle (50) using roll pin (48).

NOTE: On airplanes 20800001 Thru 20800100, if the door lock on the passenger door does not operate properly, a new cam (78) may be modified. Refer to Figure 201, Sheet 2, View B-B.

4. Upper Passenger Door Lock Key Assembly Removal/Installation

- A. Remove Upper Passenger Door Lock Key Assembly (Refer to Figure 201).
 - (1) Unlock and open the door.
 - (2) Remove the roll pin (48), interior door handle (50) and washer (47).
 - (3) Remove the door window trim moulding.
 - (4) Bend the lockwasher tab away from the nut.
 - (5) Remove the two screws, lockwashers, cam (78), nut and lockwasher from the back of the lock assembly.
 - (6) Remove the lock assembly (71) from the door.
 - B. Install Upper Passenger Door Lock Key Assembly (Refer to Figure 201).
 - (1) Position the lock assembly (71) through opening in front of door.
 - (2) Assemble the lock as follows:
 - (a) Install the lockwasher and nut on the lock assembly; tighten nut. To prevent nut from loosening, bend lockwasher tab against one flat of the nut.
- CAUTION:** Do not use too much Loctite 242 adhesive or it could get into the lock and ruin it.
- (b) Put one drop of Loctite 242 on the two screws and install cam (78), lockwashers and screws on the lock assembly; tighten screws.
 - (3) Turn the key and lock to make sure that the cam (78) and pin (69) engages and disengages the latch.
 - (4) Operate the door linkage from outside to ensure proper operation.
 - (5) Install the door window trim moulding.
 - (6) Install the washer (47) and interior door handle (50) using roll pin (48).
- C. For Key Lock Lubrication, refer to Chapter 12, Key Locks - Servicing - Servicing Key Lock Lubrication.

5. Lower Passenger Door Removal/Installation

- A. Remove Lower Passenger Door (Refer to Figure 202).
 - (1) With upper and lower door open, support lower door.
 - (2) Remove nuts (6), lockwashers (7), and washers (8) attaching forward and aft gas spring dampeners (5) to mounting plates (9) on lower door.
 - (3) Disconnect lower ends of forward and aft cable assemblies by removing screws (40) and spacers (43).
 - (4) Remove six bolts (19) and six washers (20), attaching upper hinge (17) to fuselage, then remove step tread (18).
 - (5) Remove four remaining screws (21) attaching upper hinge (17) to fuselage.
 - (6) Slide door and hinge out from between fuselage and door jambs,

NOTE: If lower door dampener is removed, it should be tagged to identify it as being used on lower door. Upper gas spring and lower door dampener are identical except for pounds of force. Upper gas spring has 45 pounds of force (Airplanes 20800001 Thru 20800058), or 60 pounds of force (Airplanes 20800059 and On). Lower snubber has 6 pounds of force (Airplanes 20800001 Thru 20800095), except when modified per CAB 86-11. Both have the same placard installed on cylinder. To determine difference between upper gas spring and lower door dampener, push in on cylinder rod. If rod cannot be compressed easily, the cylinder is an upper door gas spring. If upper door gas spring or lower door dampener is replaced with a new part, the replaced part must be disposed of in accordance with Cargo Door - Maintenance

Practices, Disposal of Gas Spring Cylinder.

- B. Install Lower Passenger Door (Refer to Figure 202).
- (1) Slide door hinge in between fuselage and door jambs, align holes in fuselage with holes in hinge and install four screws (21).
 - (2) Align holes in step tread (18) with holes in fuselage and install six washers (20) and six bolts (19).
 - (3) Connect lower ends of forward and aft cable assemblies (42) using spacers (43) and screws (40).
 - (4) Install gas spring dampeners using washers (8), lockwashers (7), and nuts (6).
 - (5) Make sure the door gap is correct. Refer to Passenger Door Gap Adjustment in this section.

6. Passenger Door Step Disassembly/Assembly

- A. Disassemble Passenger Entry Door Step Assembly (Refer to Figure 202).
- (1) Remove step assembly from lower door. Refer to Remove Passenger Entry Door Step Assembly.
 - (2) Remove strap assembly (110) by removing screws (111) and spacers (112).
 - (3) Top step is now free to remove.
 - (4) To remove center step, remove nut (64), washer (63), bushing (62), spacer (61), and screw (59) from both sides of step assembly.
 - (5) The lower step is partially disassembled when cable assemblies were removed.
 - (6) To complete the removal of lower step, remove screws (71) and spacer (70) from each side of step assembly.
- B. Assemble Passenger Entry Door Step Assembly (Refer to Figure 202).
- (1) Partially install lower step by installing screw (71) through step rail with spacer (70) between step rail and step, on each side of step assembly.
 - (2) Install strap (110) on center step assembly using screw (111) and spacer (112).
 - (3) Install center step using screw (59) through step rail, spacer (61) between step rail and step, bushing (62) through mounting hole in step, then install washer (63) and nut (64) on each side of step assembly.
 - (4) To complete assembly of step, refer to Crew Doors - Maintenance Practices.
 - (5) Torque all step assembly screws to 70 inch-pounds, +0 or -5 inch-pounds, plus running torque.

NOTE: Refer to Chapter 20, Torque Data - Maintenance Practices, for information on torquing of bolts.

7. Passenger Entry Door Step Assembly Removal/Installation

- A. Remove Passenger Entry Door Step Assembly (Refer to Figure 202).
- (1) With upper and lower door open, support lower door.
 - (2) Disconnect forward and aft cable assemblies (42) from step assembly (69) by removing screws (40) and spacers (43).
 - (3) Remove nut (49), washer (48), bushing (47), spacer (46), spacer (45), washer (30), and screw (31) from each side of step assembly.
 - (4) Remove nut (56), washer (54), spacer (55), washer (32), and screw (33) from each side of step assembly.
 - (5) Remove nut (60), washer (57), spacer (58), washer (34), and screw (35) from each side of step assembly and remove step assembly.
- B. Install Passenger Entry Door Step Assembly (Refer to Figure 202).
- (1) Align holes in step assembly with holes in door rails.
 - (2) Install screw (31) with washer (30) through door rail, install spacer (45) between door rail and step rail, install spacer (46) between step rail and step, insert bushing (47) into step mounting hole, then install washer (48) and nut (49) on each side of step assembly.
 - (3) Install screw (33) with washer (32) through door rail, install spacer (55) between door rail and step rail, then install washer (54) and nut (56) on each side of step assembly.
 - (4) Install screw (35) with washer (34) through door rail, install spacer (58) between door rail and step rail, then install washer (57) and nut (60) on each side of step assembly.
 - (5) Connect forward and aft cable assemblies using spacers (43) and screws (40).

- (6) Torque all step assembly mounting screws to 70 inch-pounds, +0 or -5 inch-pounds, plus running torque.

NOTE: Refer to Chapter 20, Torque Data - Maintenance Practices, for information on torquing of bolts.

8. Lower Passenger Door Latching Mechanism Removal/Installation

- A. Remove Lower Passenger Door Latching Mechanism (Refer to Figure 202).
- (1) Remove roll pin (101), remove handle (100), and washer (102).
 - (2) Remove escutcheon (98) by removing two screws (99).
 - (3) Remove door panel.
 - (4) Remove two screws (109), shims (73) and latch pin guide (72).
 - (5) Remove washer (74), spring (75), cup (108), and washer (107) from latch pin (104).
 - (6) Remove cotter pin (77), pin (105), and latch pin (104).
 - (7) Remove cotter pin (79), pin (103), and pushrod (78).
 - (8) Remove two screws (88), shims (73), and latch pin guide (72).
 - (9) Remove cotter pin (86), pin (89), and latch pin (87).
 - (10) Remove cotter pin (79), pin (103), and pushrod (85).
- B. Install Lower Passenger Door Latching Mechanism (Refer to Figure 202).
- (1) Connect pushrod (85) to bellcrank (83) using pin (103) and cotter pin (79).
 - (2) Insert latch pin (87) into guide (72) and install shims (73) and guide (72) using two screws (88).
 - (3) Connect latch pin (87) to pushrod (85) using pin (89) and cotter pin (79).
 - (4) Connect pushrod (78) to bellcrank (83) using pin (103) and cotter pin (86).
 - (5) Connect latch pin (104) to pushrod (78) using pin (105) and cotter pin (77).
 - (6) Install washer (107), cup (108), spring (75), and washer (74) on latch pin (104).
 - (7) Insert end of latch pin (104) into guide (72), install shims (73) and guide (72) using two screws (72).
 - (8) Install door panel.
 - (9) Install escutcheon using two screws (99).
 - (10) Install washer (102) and handle (100), secure by installing roll pin (101).

9. Upper and Lower Passenger Doors Adjustment/Test

CAUTION: Do not adjust the bonded door flange or the airplane structure with force. The bonded areas and the structural components can be damaged.

- A. Passenger Door Gap Adjustment.
- (1) Determine the existing gap by fully closing and latching the passenger door.

NOTE: The gap between the door and adjacent fuselage skin should be 0.06 inch, +0.03 or -0.00 inch (1.52 mm, +0.76 mm or -0.00 mm).
 - (2) If the door gap is incorrect, trim the door as needed to achieve the correct gap.
 - (3) Close and latch the passenger door and recheck gap. Repeat the trim procedure as needed to obtain the correct gap.
 - (4) After trimming the door, prime and paint to match surrounding area. Refer to Chapter 12, External-Cleaning/Painting.
- B. Adjustment/Test Procedure (Refer to Figure 203).
- (1) With upper section door handle (50) in locked position, adjust the clevis end of pushrods by loosening jamnut to obtain 0.91 inch, +0.10 or -0.10 inch from outer edge of door rail to the end of latch pins. After adjusting, tighten jamnuts.
 - (2) Adjust plunger in outer end of upper door exterior handle using slot screwdriver. To tighten, turn clockwise; to loosen, turn counterclockwise. Adjust plunger until 10 pounds, + 5 or -0 pounds of force, applied at 0.55 inch from end of inboard handle, is required to disengage plunger from catch plate.
 - (3) To adjust the latch pins in lower door section, refer to step one.

10. Gas Spring/Upper Door Test Procedure

- A. When gas spring operation problems are suspected on upper passenger door, the following test procedure should be

used. The forces are measured with a spring ambient temperature of 68°F, +2 or -2°F, with piston rod extending downwards.

- (1) Obtain direct reading sensitive scale.
- (2) Remove pneumatic extender from airplane.
- (3) Grasp extender by cylinder in a vertical position with piston rod end down, and place on sensitive scale.
- (4) Compress device fully four or five times with piston rod end down. (This lubricates seals and piston.)
- (5) Compress approximately 1.5 inch and relax pressure slightly to allow piston rod to extend slowly until it is approximately 0.20 inch from full extension. Hold steady and read pressure.
- (6) An acceptable extender will read between 42 and 52 pounds on scale.

11. Passenger Door Seals Removal/Installation

A. Remove Passenger Door Seals.

- (1) Remove door seal. A putty knife may be used to aid in the removal of seal. Caution must be taken not to damage door.
- (2) Clean off old adhesive from bonding surface with a cloth slightly dampened with methyl n-propyl ketone, taking care to apply methyl n-propyl ketone to bonding surface only.

B. Install Passenger Door Seals.

- (1) Clean bonding surface with a cloth slightly dampened with methyl n-propyl ketone. Do not allow methyl n-propyl ketone to contact painted surface.

NOTE: On Airplanes 20800001 Thru 20800108 and 208B0001 Thru 208B0003, the straight portion of seal is neoprene rubber and corners are silicone. Beginning with Airplanes 20800109 and 208B0004 (and all spares), the entire seal is silicone.

NOTE: Trim flange of seal as required to clear latch pins and mounting hardware.

- (2) Bond neoprene seals to door using EC1300L per manufacturer's instructions.
- (3) Bond silicone seals to door using RTV- 157 per manufacturer's instructions.
- (4) After installation, clean door seals with a cloth slightly dampened with methyl n-propyl ketone. Caution must be taken not to soak seals, as methyl n-propyl ketone will soften the adhesive.

12. Door Seal Cleaning

A. Clean Door Seals

CAUTION: Caution must be taken not to oversoak the seals with methyl n-propyl ketone, as methyl n-propyl ketone will soften the adhesive, neoprene rubber seals, and silicone seals.

- (1) It is important that all door seals are properly secured and cleaned periodically to ensure an air and water tight seal. Clean door seals with a cloth, slightly dampened with methyl n-propyl ketone.

Figure 201 : Sheet 1 : Upper Passenger Door Installation

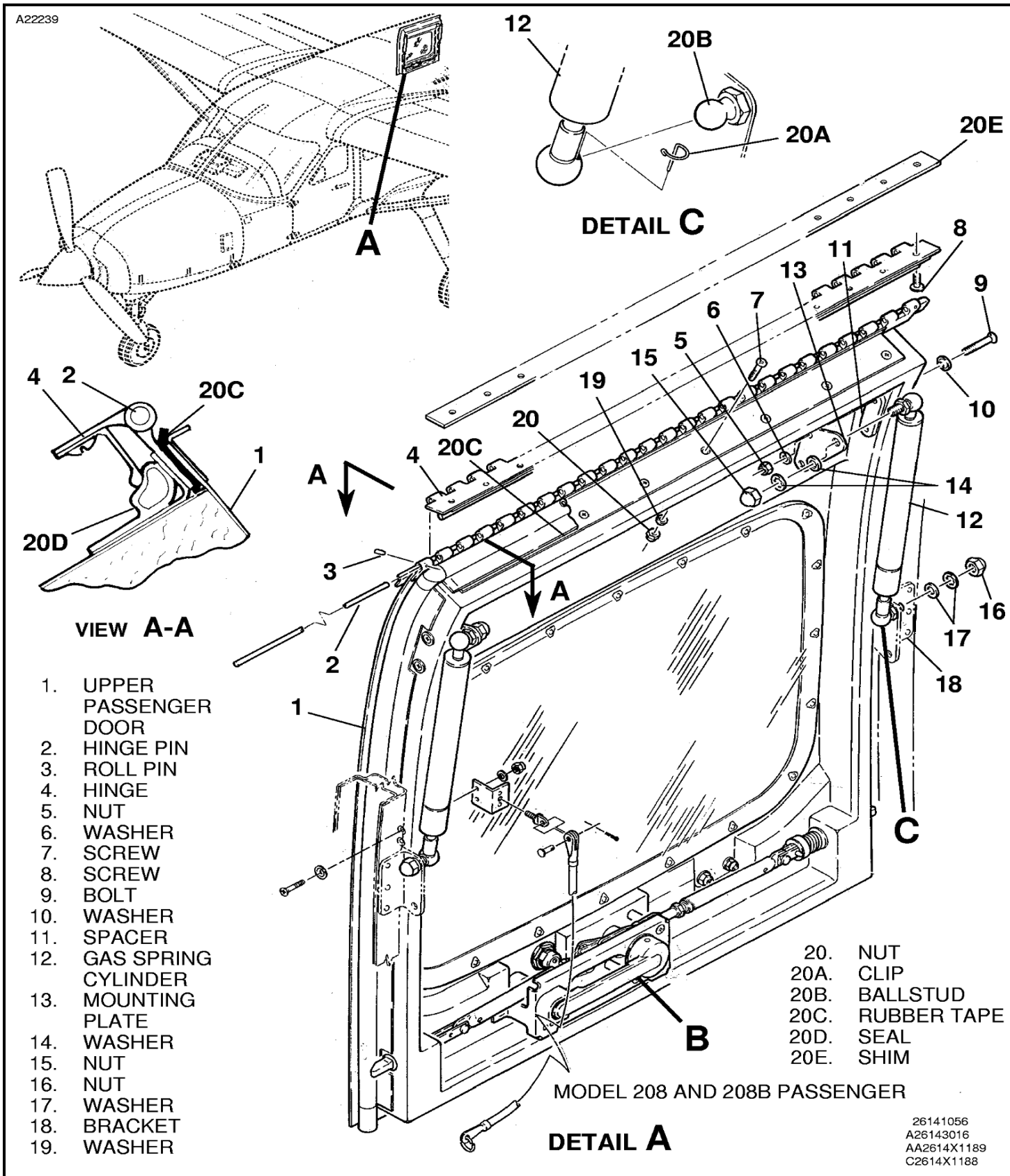

Figure 201 : Sheet 2 : Upper Passenger Door Installation

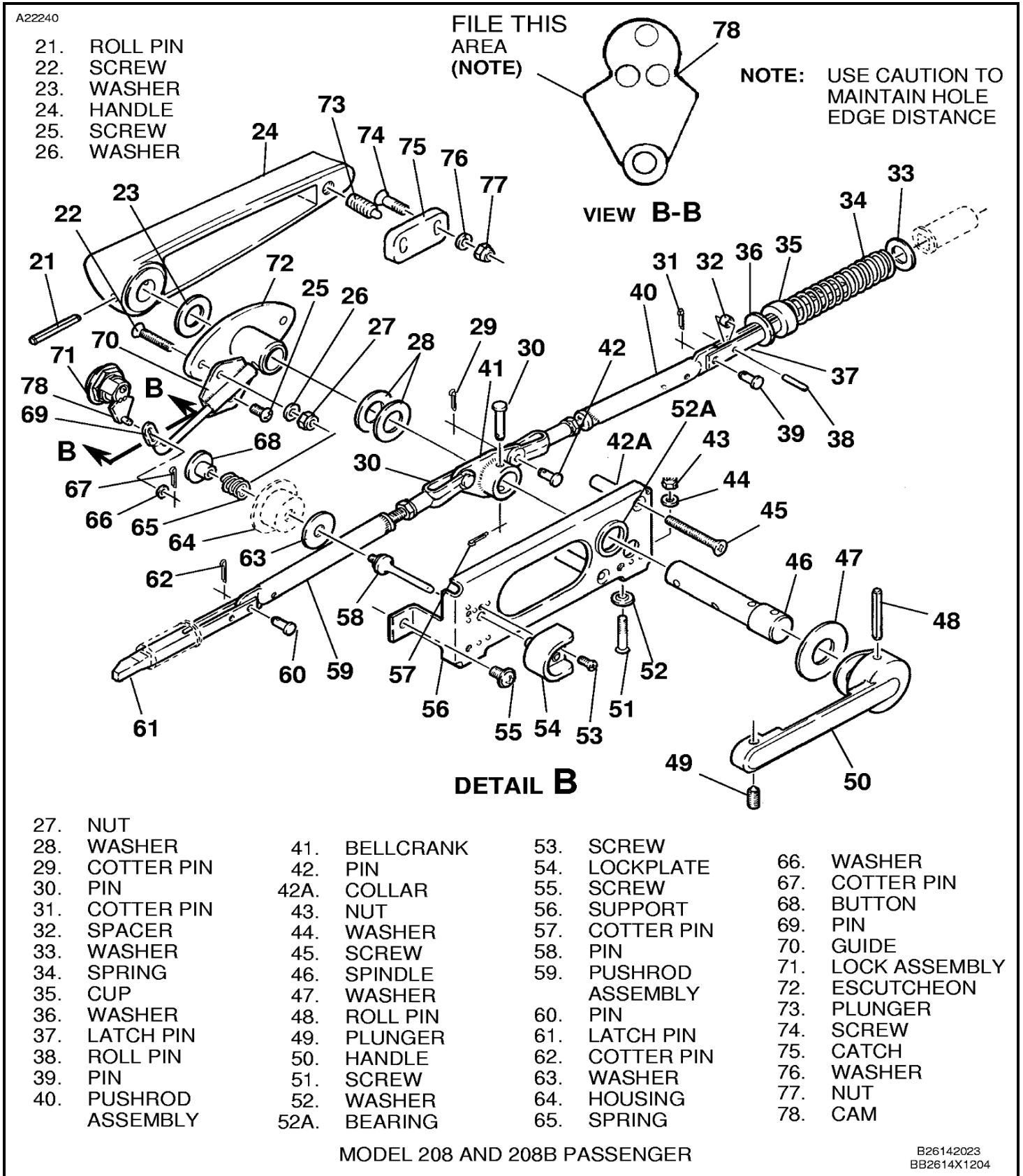
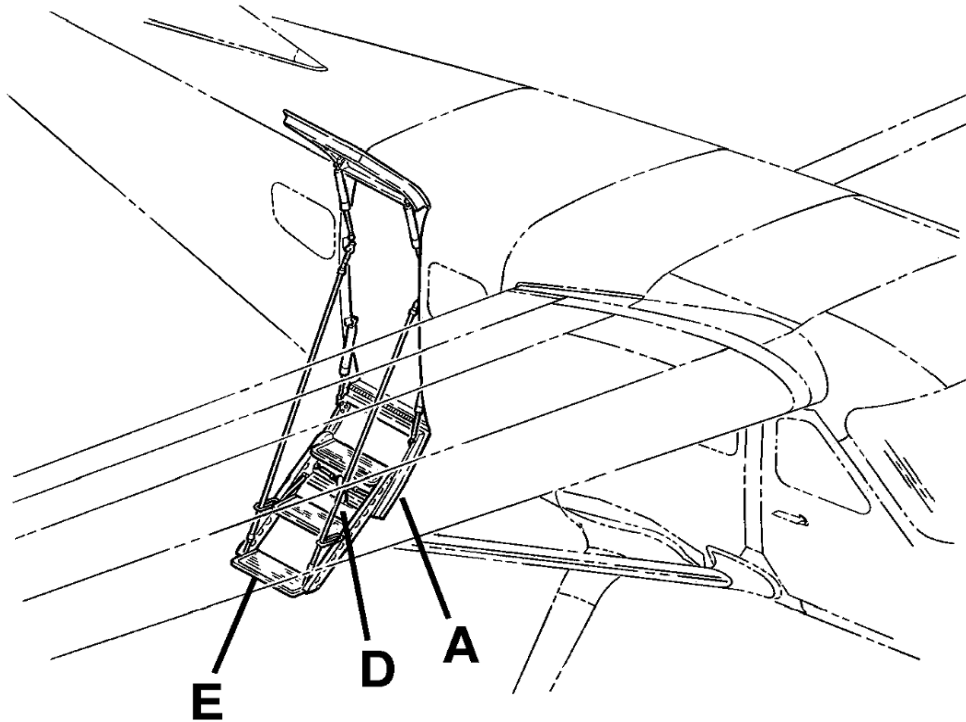

Figure 202 : Sheet 1 : Lower Passenger Door Installation

A22242



MODEL 208 AND 208B PASSENGER

26142025

Figure 202 : Sheet 2 : Lower Passenger Door Installation

A22243

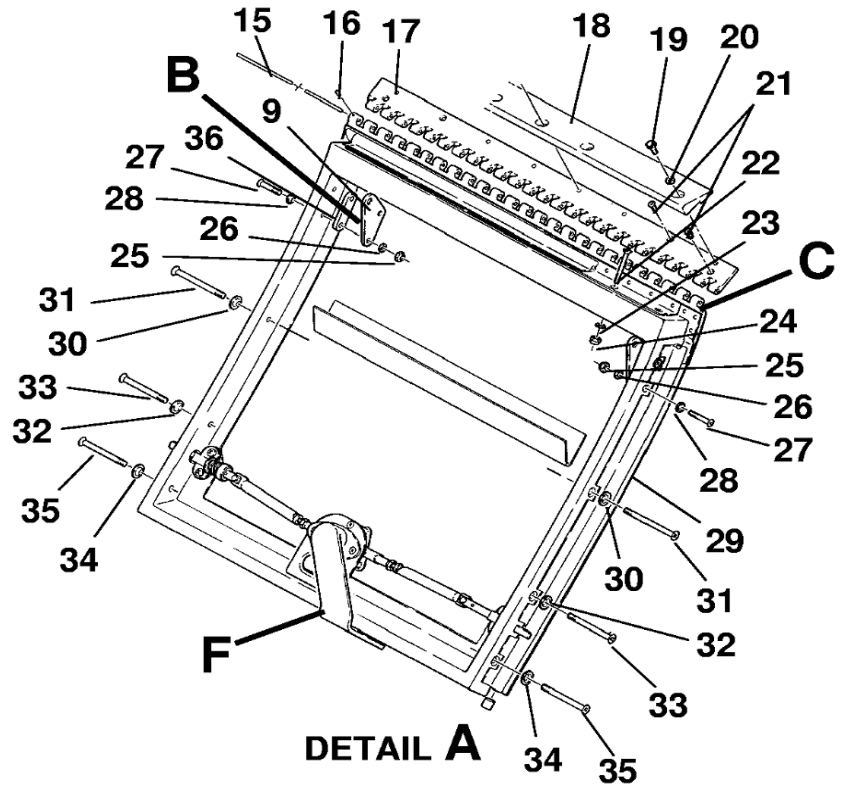
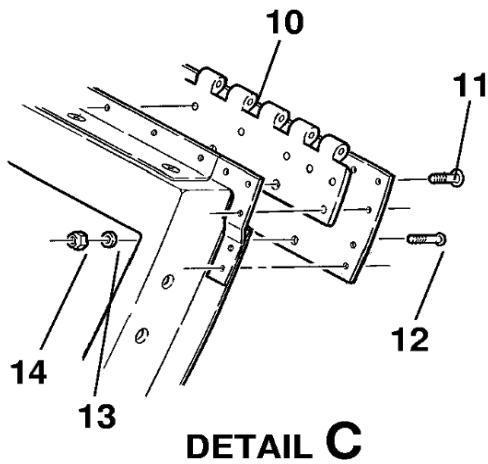

1. NUT
2. LOCKWASHER
3. WASHER
4. BRACKET
5. GAS SPRING DAMPENER
6. NUT
7. LOCKWASHER
8. WASHER
9. MOUNTING PLATE
10. LOWER HINGE
11. SCREW
12. SCREW
13. WASHER
14. NUT
15. HINGE PIN
16. ROLL PIN
17. UPPER HINGE
18. STEP TREAD
19. BOLT
20. WASHER
21. SCREW
22. SCREW
23. WASHER
24. NUT
25. NUT
26. WASHER
27. SCREW
28. WASHER
29. LOWER DOOR
30. WASHER
31. SCREW
32. WASHER
33. SCREW
34. WASHER
35. SCREW
36. SPACER

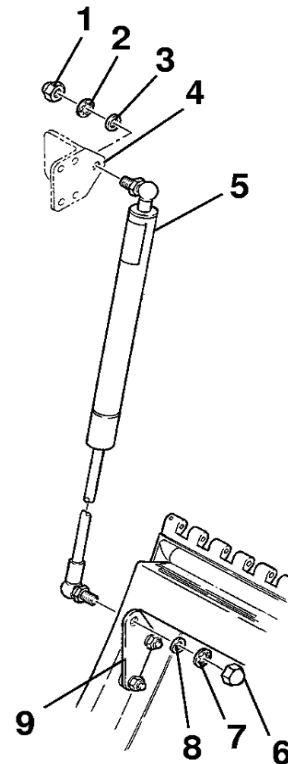

MODEL 208 AND 208B PASSENGER

A26144006
B26142027
C26141055

Figure 202 : Sheet 3 : Lower Passenger Door Installation

A22244

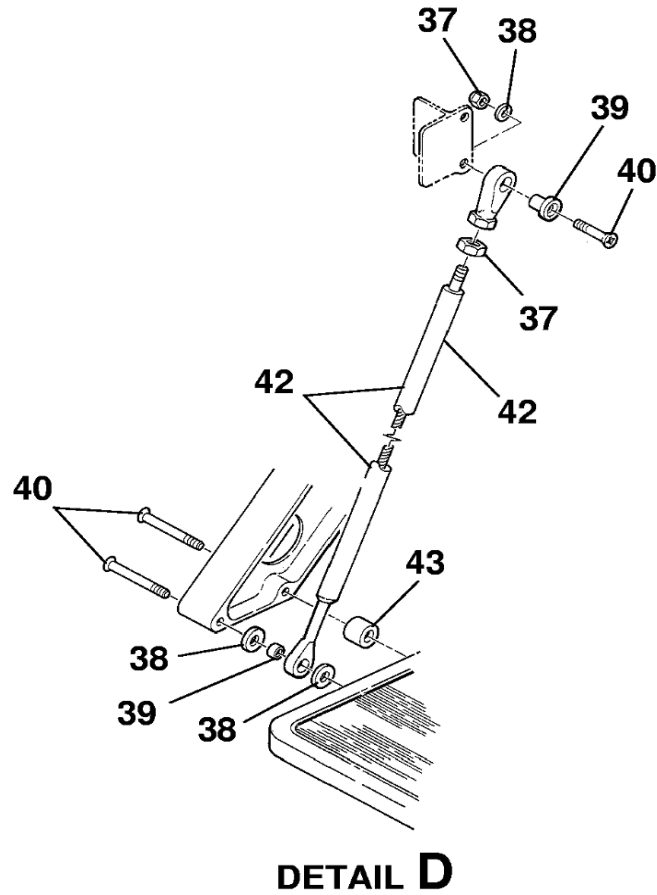

- 37. NUT
- 38. WASHER
- 39. BUSHING
- 40. SCREW
- 42. CABLE ASSEMBLY
- 43. SPACER

MODEL 208 AND 208B PASSENGER

D26142026A

Figure 202 : Sheet 4 : Lower Passenger Door Installation

A22246

- 45. SPACER
- 46. SPACER
- 47. BUSHING
- 48. WASHER
- 49. NUT
- 50. NUT
- 51. WASHER
- 52. SPACER
- 53. SCREW
- 54. WASHER
- 55. SPACER
- 56. NUT
- 57. WASHER
- 58. SPACER
- 59. SCREW
- 60. NUT
- 61. SPACER
- 62. BUSHING
- 63. WASHER
- 64. NUT
- 65. SPACER
- 66. SCREW
- 67. WASHER
- 68. NUT
- 69. STEP ASSEMBLY
- 70. SPACER
- 71. SCREW
- 110. STRAP
- 111. SCREW
- 112. SPACER
- 113. NUT
- 114. SCREW
- 115. CABLE GUIDE
- 116. SUPPORT ASSEMBLY
- 117. SCREW
- 118. WASHER

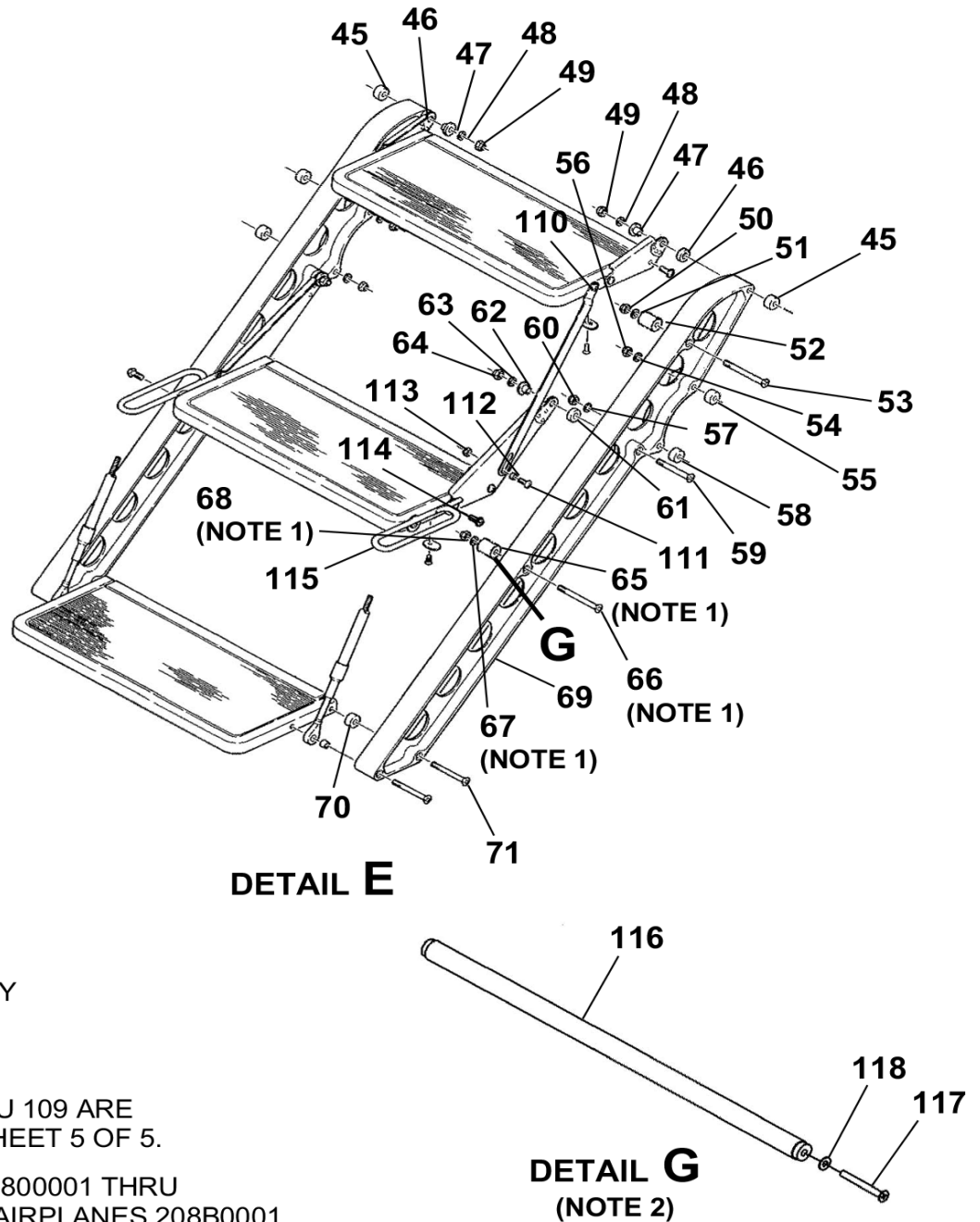

NOTE: ITEMS 72 THRU 109 ARE SHOWN ON SHEET 5 OF 5.

NOTE 1: AIRPLANES 20800001 THRU 20800275 and AIRPLANES 208B0001 THRU 208B0661 NOT INCORPORATING SK208-134

NOTE 2: AIRPLANES 20800276 AND ON and AIRPLANES 208B0662 AND ON and AIRPLANES 20800001 THRU 20800275 and AIRPLANES 208B0001 THRU 208B0661 INCORPORATING SK208-134

MODEL 208 AND 208B PASSENGER

E26144006
G26144006

Figure 202 : Sheet 5 : Lower Passenger Door Installation

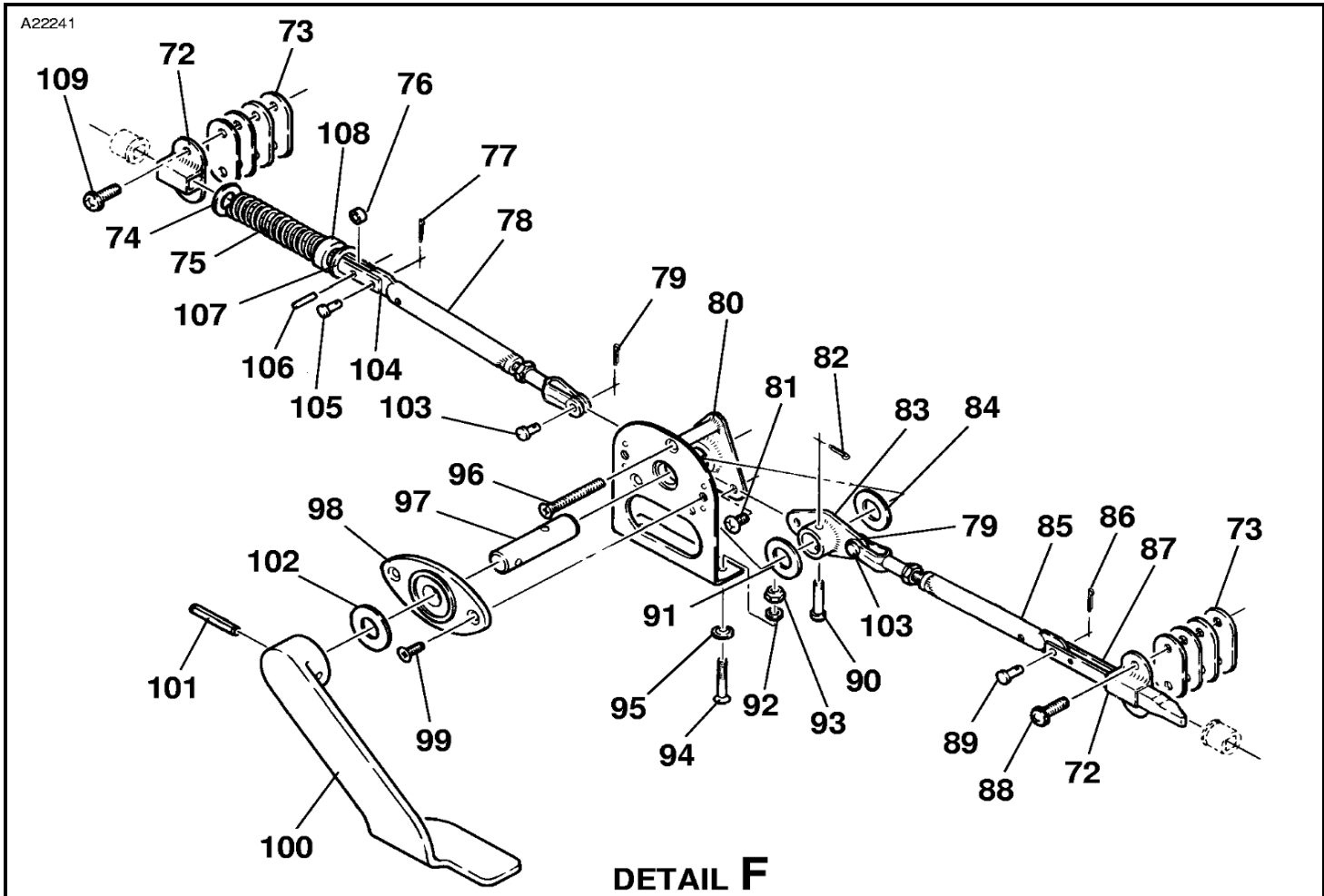

DETAIL F

- | | | |
|----------------------|----------------|------------|
| 72. GUIDE | 90. PIN | 108. CUP |
| 73. SHIM | 91. WASHER | 109. SCREW |
| 74. WASHER | 92. WASHER | |
| 75. SPRING | 93. NUT | |
| 76. SPACER | 94. SCREW | |
| 77. COTTER PIN | 95. WASHER | |
| 78. PUSHROD ASSEMBLY | 96. SCREW | |
| 79. COTTER PIN | 97. SPINDLE | |
| 80. SUPPORT ASSEMBLY | 98. ESCUTCHEON | |
| 81. SCREW | 99. SCREW | |
| 82. COTTER PIN | 100. HANDLE | |
| 83. BELLCRANK | 101. ROLL PIN | |
| 84. WASHER | 102. WASHER | |
| 85. PUSHROD ASSEMBLY | 103. PIN | |
| 86. COTTER PIN | 104. LATCH PIN | |
| 87. LATCH PIN | 105. PIN | |
| 88. SCREW | 106. ROLL PIN | |
| 89. PIN | 107. WASHER | |

MODEL 208 AND 208B PASSENGER

F26143017

Figure 203 : Sheet 1 : Upper and Lower Passenger Doors

A22245

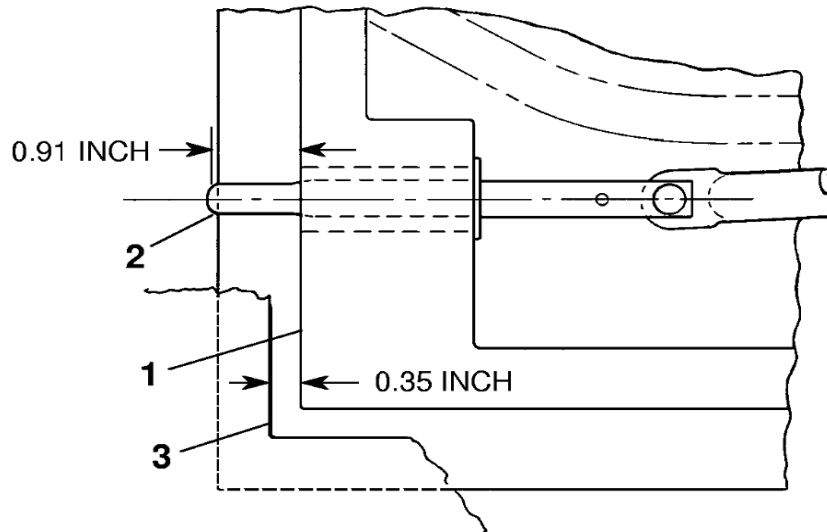

TYPICAL

- 1. OUTER DOOR RAIL
- 2. LATCH PIN
- 3. DOOR JAMB

MODEL 208 AND 208B PASSENGER

2614X1205